

# Dual 701

Automatic single play turntable  
with electronically regulated direct drive



**Dual**® Owner's manual

## Contents.

|                      |                            |
|----------------------|----------------------------|
| <b>Page 2 (flap)</b> | Introduction.              |
| <b>Page 3 (flap)</b> | Features of the Dual 701.  |
| <b>Page 4</b>        | Operating instructions.    |
| <b>Page 5</b>        | Direct-drive motor.        |
| <b>Page 6-7</b>      | Tonearm of the Dual 701.   |
| <b>Page 8-9</b>      | Installation instructions. |

## Introduction.

Although the Dual 701 is a highly sophisticated turntable, you will probably find it simpler and easier to operate than any other turntable you have owned. For example, one operating switch controls all automatic start and stop functions of the motor and tonearm. And whether you start it manually or automatically, play can be interrupted at any time, either manually or automatically.

Thus, much of this owner's manual is devoted to a description of the 701's advanced features, especially the electronically regulated direct-drive motor and the mechanical filters.

We do suggest, however, that you follow the cartridge-mounting instructions with some care. As with any tonearm, the stylus must be in the correct position for optimum performance. We are confident that you will now enjoy your records more than ever before.

If you have any questions about the 701's operation or performance, we hope you will write to us. In any case, we would appreciate your comments on the warranty card which we urge you to complete and send in for proper registration of your 701.

# Electronically controlled direct-drive DC motor.

The most unusual feature of the Dual 701 is its motor/and direct drive system.

Unlike conventional AC motors which rotate at high speeds (usually 1800 rpm) and must be coupled to the platter by speed-reducing idlers or belts, the 701 rotor itself rotates at the selected record speed, (33-1/3 or 45 rpm). Thus, the platter is driven directly by the rotor, and the record spindle is actually the top of the motor shaft.

The 701 motor is a DC type which receives its energy from a regulated power supply, and is thus independent of variations in line voltage or frequency. A pair of Hall-effect devices, built into the motor, trigger four switching semiconductors which produce a rotating field in the motor's magnetic field coil. The magnetic rotor rotates with this field, carrying the platter which rests directly on the rotor assembly.

Motor speed is subject to instantaneous self-correction by means of a feedback circuit controlling the current fed to the motor from the regulated power supply. Since this correction is both continual and instantaneous, speed variations are theoretical rather than actual.

A special feature of the 701 motor is the use of its overlapping field coils. This significant design feature eliminates the successive pulses of magnetic flux typical of all other motor designs. By eliminating these pulses, the 701 motor also eliminates a major source of vibration and rumble inherent in all other motor designs.

Because the low motor speed and overlapping field coils make the 701 motor so free of vibration, unlike conventional motors it can be mounted directly to the chassis without risk of transmitting vibration to the tonearm.

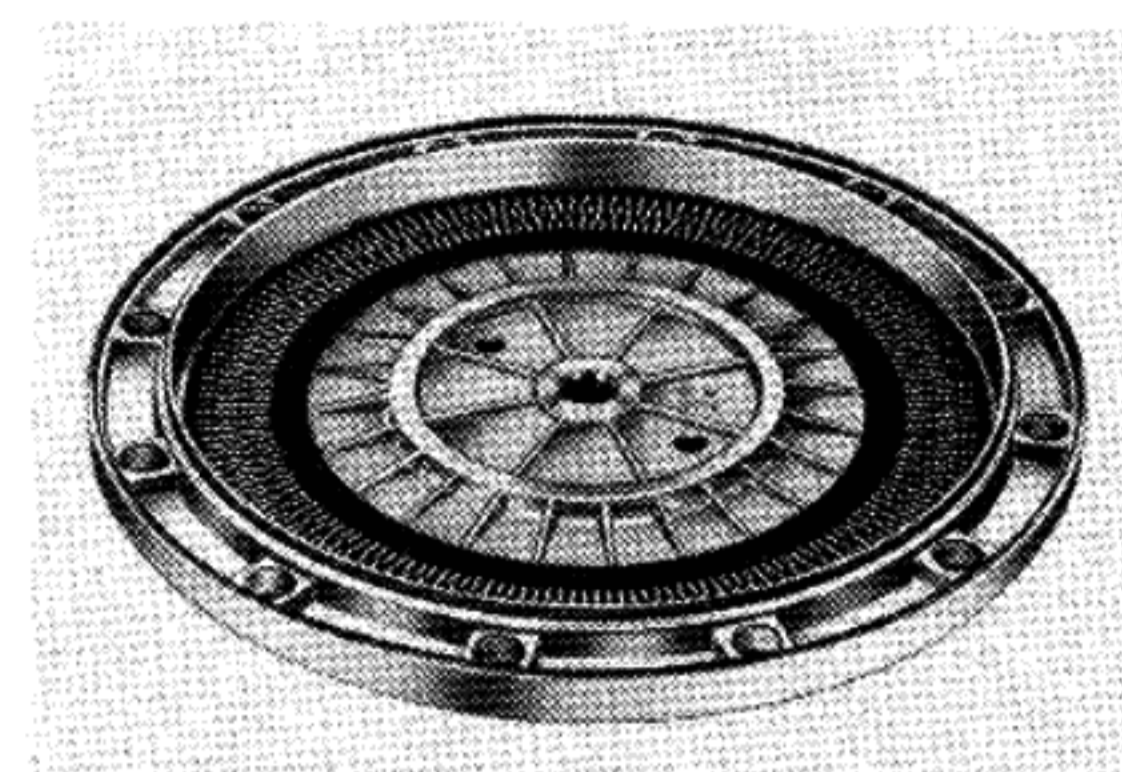
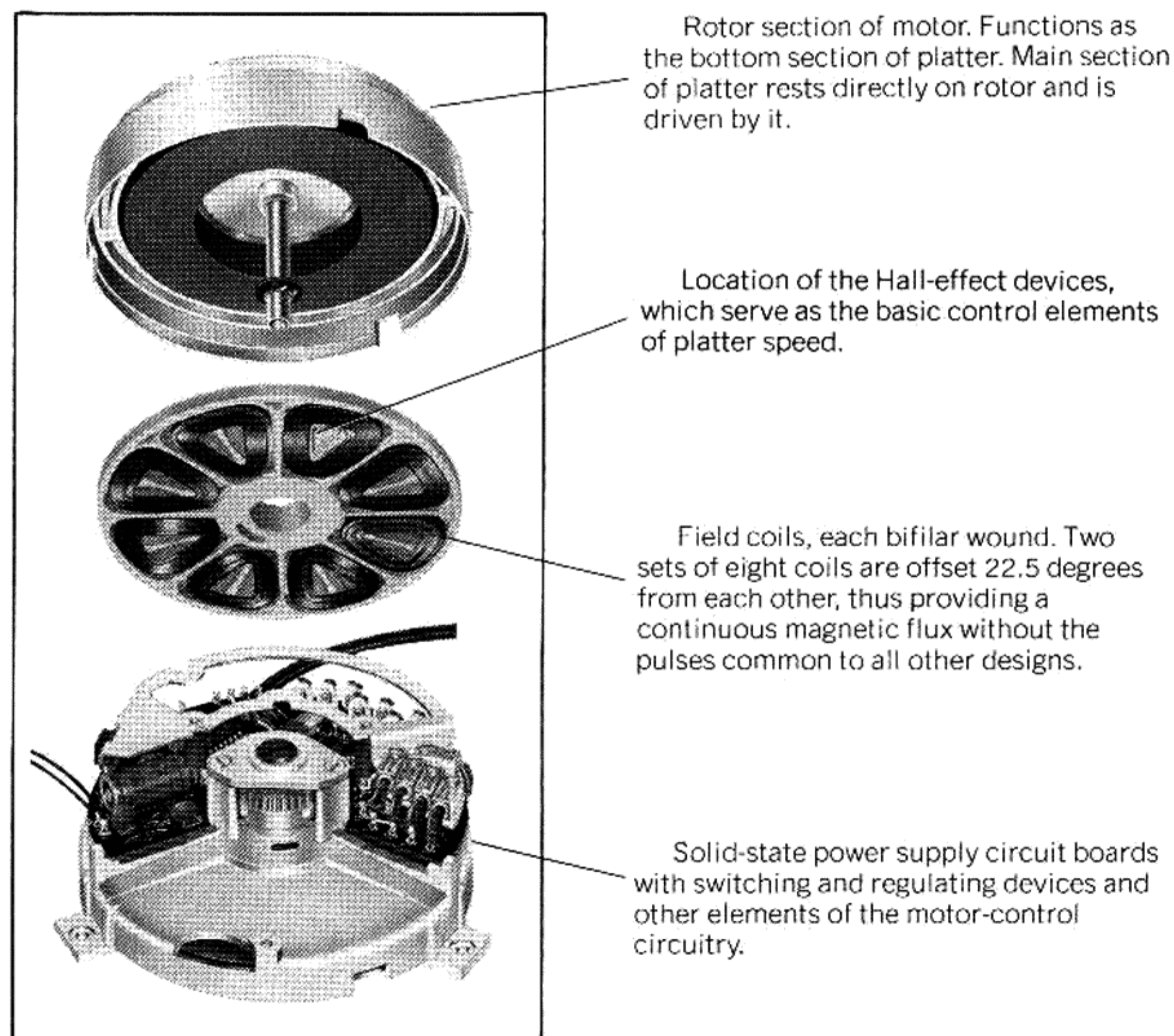

Fig. 7. Underside of 701 platter.

## Twelve-inch dynamically balanced platter.

The platter of the 701 actually consists of two parts. The top portion on which the record rests, is a one-piece nonferrous die-casting, 12 inches in diameter and weighs 6 pounds and 10 ounces. The lower portion, which is actually the rotor, contributes additional weight. Both portions are dynamically balanced. **Note:** Since the two platter sections are separate pieces, the upper section must always be removed and carried separately whenever the 701 is moved.



Rotor section of motor. Functions as the bottom section of platter. Main section of platter rests directly on rotor and is driven by it.

Location of the Hall-effect devices, which serve as the basic control elements of platter speed.

Field coils, each bifilar wound. Two sets of eight coils are offset 22.5 degrees from each other, thus providing a continuous magnetic flux without the pulses common to all other designs.

Solid-state power supply circuit boards with switching and regulating devices and other elements of the motor-control circuitry.

Fig. 6. Exploded view of 701 motor, showing the elements of its unique design.

# Tonearm of the Dual 701.

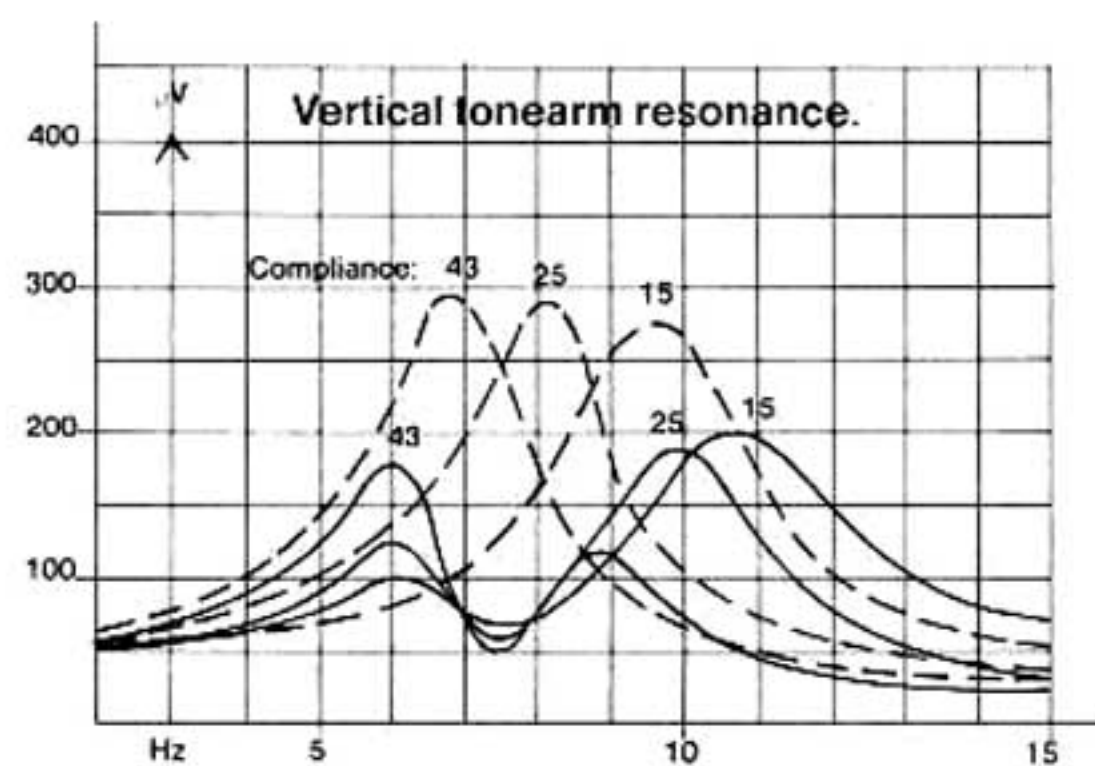

**Fig. 8.** Curves show how the tonearm/cartridge anti-resonant filter attenuates the resonance of three cartridges, each weighing 4.5 grams and with stylus compliances of 15, 25 and 43. Broken lines show resonance without filter; solid lines show attenuated resonance with filter.

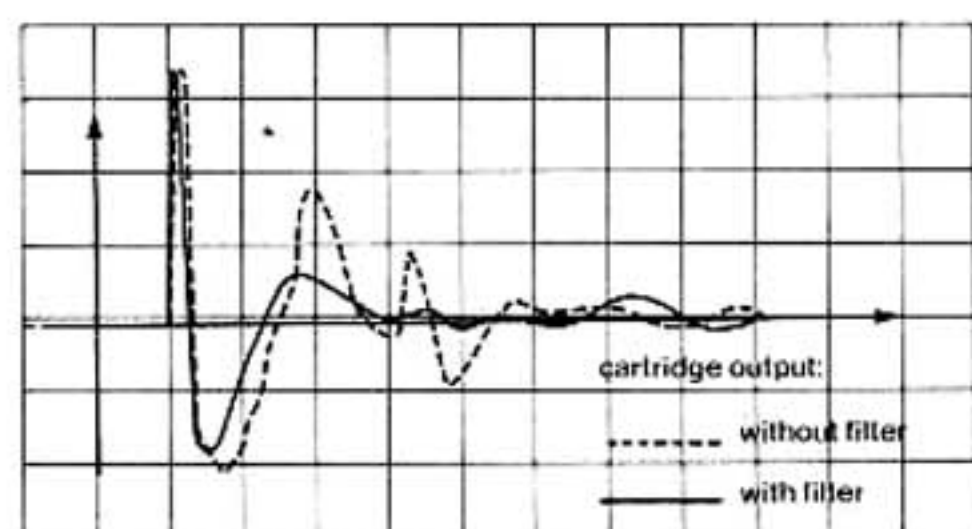

**Fig. 9.** Influence of anti-resonant filter is shown when tonearm is dropped on grooveless record from 4mm height. Resonance is quickly damped out by filter, whereas resonant influence continues much longer without filter.

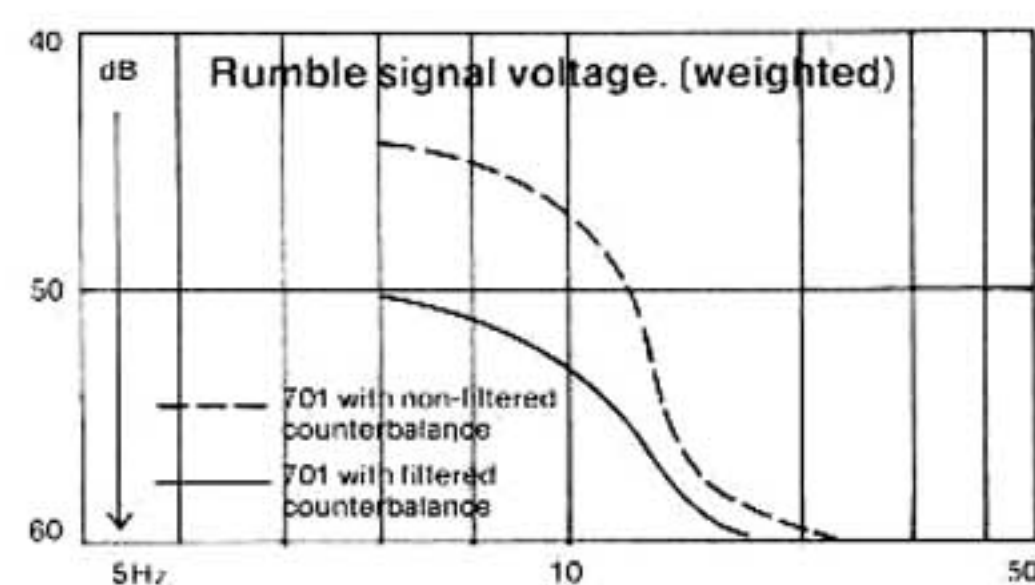

**Fig. 10.** Filter tuned to resonance frequency of chassis attenuates resonances in rumble range. Effectiveness of filter is compared with use of similar but non-filtered counterbalance.

## A brief explanation of resonance and the mechanical filters.

Tonearms, turntables and cartridges have mechanical resonances as do all physical objects. Such resonances interfere in record playback performance by introducing peaks and dips in the frequency response of the cartridge, by causing spurious low-frequency peaks, and by excessive sensitivity to acoustical feedback.

Various damping and coupling techniques have been used over the years to minimize these effects of resonance—with varying but modest degrees of success. The ideal solution for tonearm resonance would be to eliminate its effect on stylus performance. In the Dual 701, this is accomplished by two separate mechanical filters housed within the tonearm counterbalance.

Each of the filters is tuned to a range of frequencies encountered by the playback system. One filter is designed to cancel the effects of the chassis and its suspension; the other is tuned to cancel the resonance of the tonearm/cartridge combination.

One final note: this solution to the problem of the unwanted effects of resonance has been accomplished without complex engineering devices which might introduce other problems.

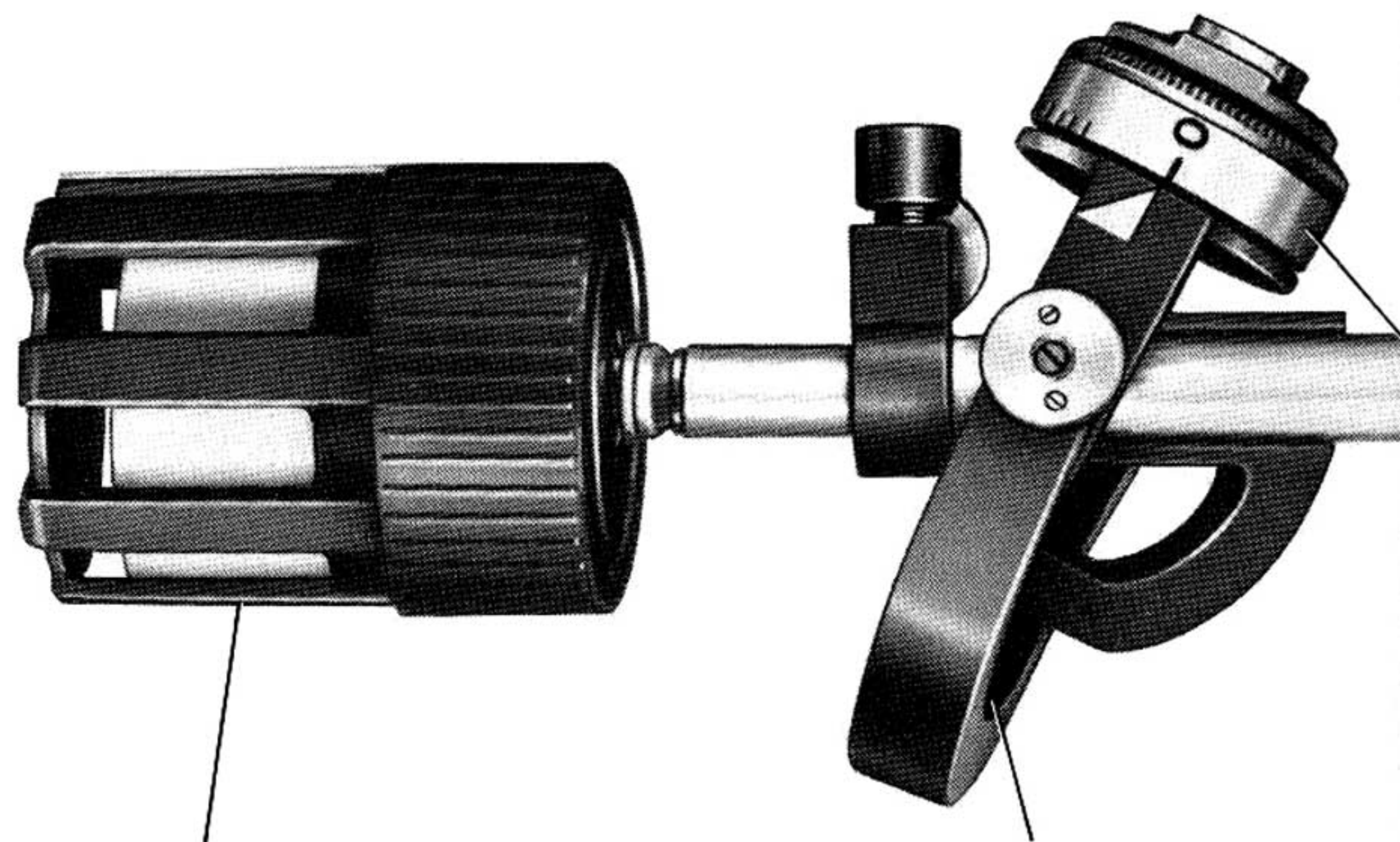

## Elastically-damped counterbalance containing mechanical resonance filters.

This unique counterbalance does more than provide the correct counterweight for the front of the tonearm including mounted cartridge. It also houses two separate mechanical filters; one is tuned to vibrate within the resonance range of the tonearm and cartridge, the other within the range of the chassis and its mounting hardware.

Unlike all other turntables which are designed to have their resonant frequencies tuned below the audible range, the Dual 701 eliminates these resonances by absorbing any energy that appears at these frequencies. The result is flatter frequency response and greater isolation from acoustical feedback.

## Four-point gimbal suspension with needle-point bearings.

All four suspension points of the tonearm are identical, low-friction, needle-point bearings. Each gimbal is hand-assembled and individually checked with gauges especially developed by Dual for this purpose.

With horizontal friction below fifteen thousandths of a gram, this tonearm is easily capable of tracking at as low as a quarter of a gram.

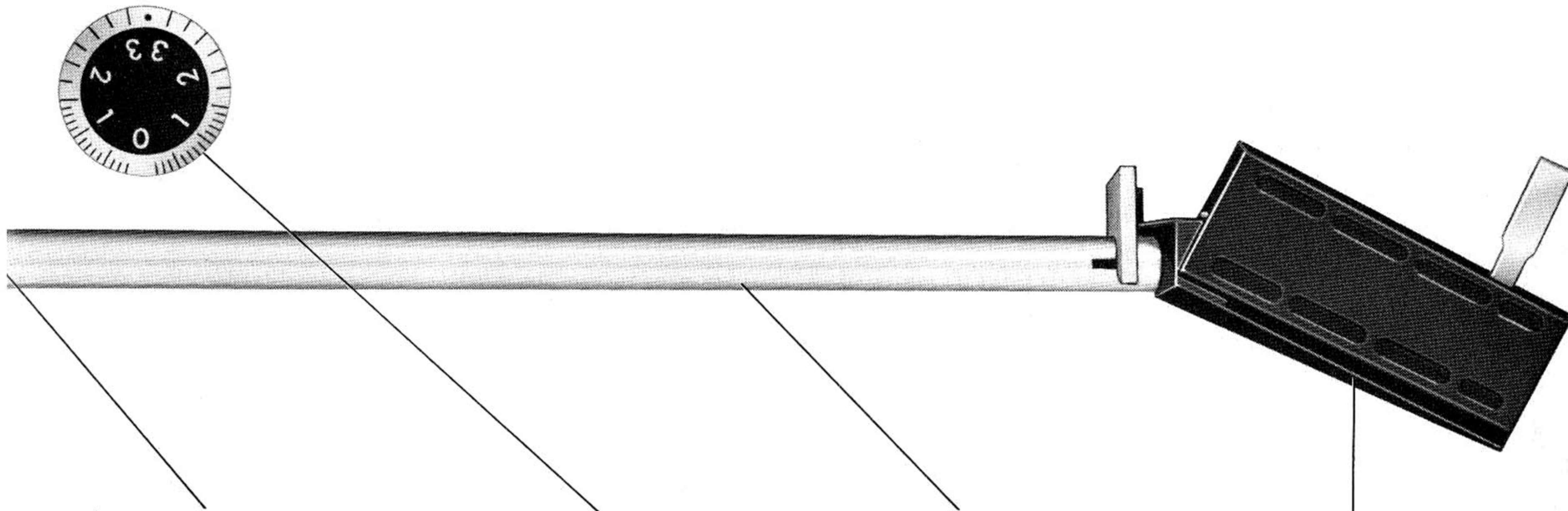

**Stylus pressure applied directly around pivot.**

To maintain perfect balance, stylus pressure is applied internally and around the pivot. This is accomplished by the use of a very long spring coiled around the pivot, only a small portion of which is needed to apply the required pressure, thus contributing greatly to the stability and accuracy of calibration.

As today's finest cartridges are designed to track at around one gram, there is little margin for error in applying optimum pressure. In the 701, therefore, the tracking pressure scale is calibrated within 0.10 gram from 0 to 1.5 grams, and within 0.25 gram from 1.5 to 3.0 grams.

**Anti-skating for both conical and elliptical stylus radii.**

The edge of the elliptical stylus that traces the groove wall is narrower than that of the conical stylus, and thus presses slightly deeper into the inner wall of the stereo groove.

As a result, more friction is created, increasing the inward pull of the groove on the stylus, and hence on the tonearm. The difference in friction between the conical and elliptical stylus is very slight, but still significant with such low bearing friction tonearms as this one. Thus, separate calibrations for each type of stylus are provided.

**Correct tonearm length and geometry for minimal tracking error.**

The 701 tonearm is  $8\frac{3}{4}$ " from stylus tip to pivot. This unusual length, plus the correct tonearm geometry essentially eliminates all horizontal tracking error. More importantly, it accomplished this without sacrificing one-piece rigidity or introducing additional points of friction.

**Quick-release cartridge holder with adjustable stylus overhang.**

The magnesium tonearm head which accepts the cartridge holder has a special slotted construction to save weight without reducing strength and rigidity.

The cartridge holder locks into the tonearm with a single movement of the tonearm/lift lever. The mounting holes are elliptical, to permit the cartridge to be moved forward and back during mounting. This allows for optimum stylus overhang to achieve minimum horizontal tracking error.

# Installation instructions.

Unpack the 701 according to the separate descriptive sheet in the carton.

The chassis is secured to the base by three self-contained transit screws. To release the chassis from its transit position, turn each screw clockwise. At mid-position, each screw will disengage. Continue to turn clockwise until each screw is "stored" in the chassis.

Now lower the platter over the top of the rotor so that the top of the motor shaft comes through the center hole of the platter.

**Note:** reverse all these procedures whenever the Dual is to be moved for any distance, and be sure to lock the transit screws in their up-positions to prevent damage.

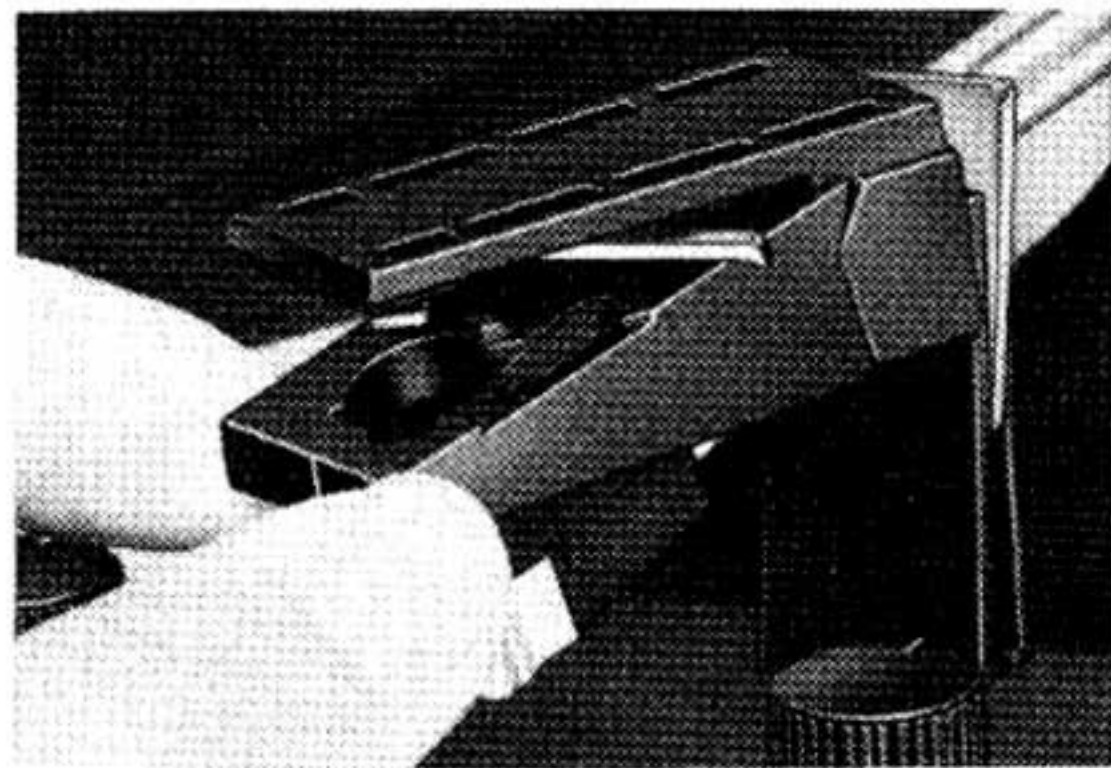
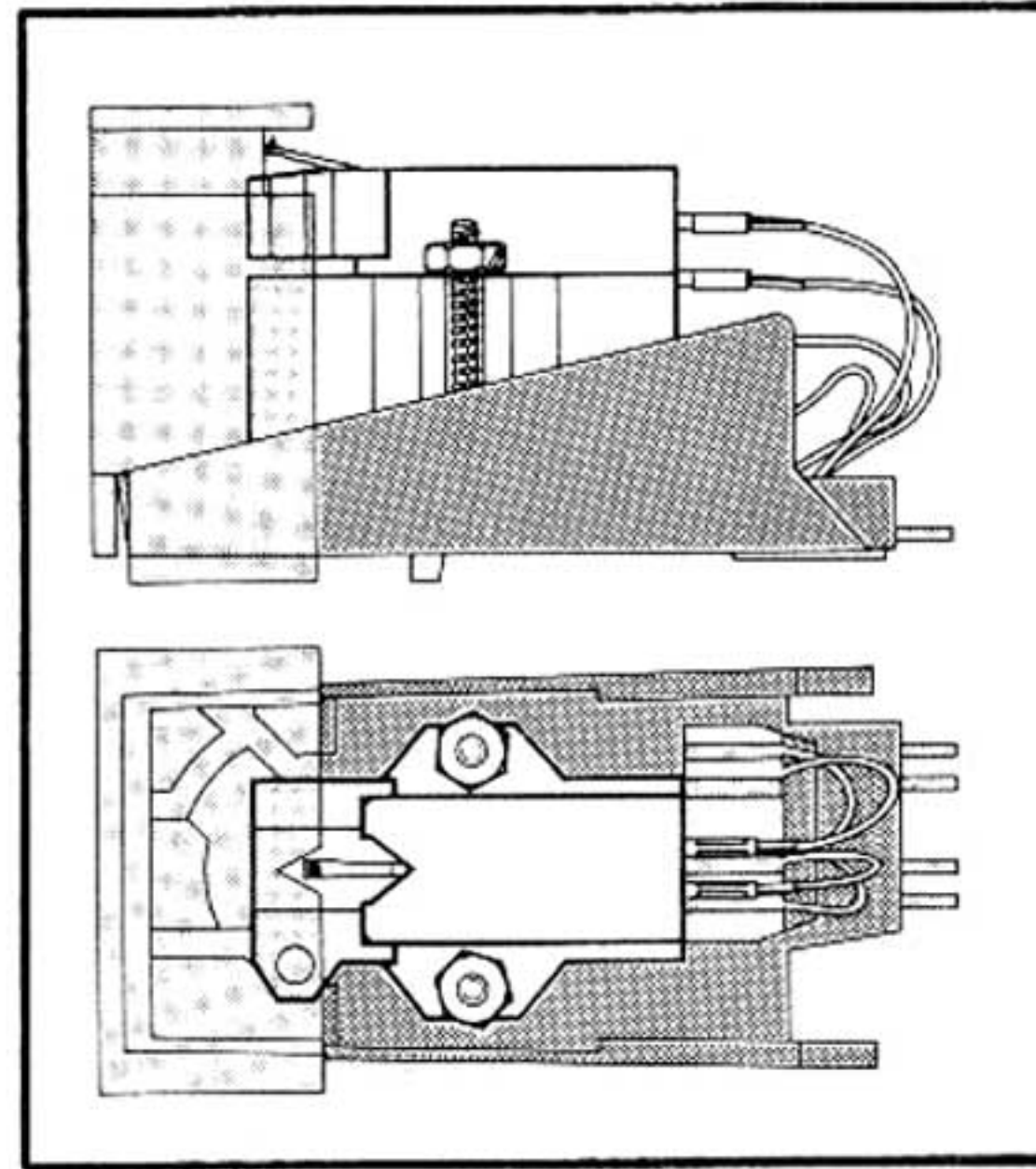

**Fig. 11. Cartridge holder with mounted cartridge.** When inserting, place upper rear edge along tonearm head first, then lift up before locking by pressing tonearm lift forward.

## Mounting the cartridge.

**Note:** The Dual 701 will accept any cartridge weighing from 1 to 10 grams (including mounting hardware) and with mounting holes spaced at the standard 1/2"

1. Release the cartridge holder from the tonearm head by pressing the tonearm lift a short turn to the rear. Be ready to catch the holder, as it will drop right into your hand. (Fig. 11.)



**Fig. 12. Gauge for checking correct depth of cartridge and overhang of stylus.**

2. From the hardware supplied with either your Dual or with your cartridge, select a pair of spacers and screws that will place the stylus tip at the correct depth from the top of the holder. The special gauge supplied with your Dual, when held against the holder as shown in Fig. 12, will give you this proper depth for the correct vertical tracking angle, plus the correct stylus overhang position for minimum horizontal tracking error. When the stylus is at the correct depth and position, it will be within the notch of the gauge.

3. Before tightening the cartridge, also be sure that it is positioned at a right angle to the front edge of the holder.

4. Connect each lead on the cartridge holder to its corresponding pin on the cartridge. Each lead is color-coded as shown in Fig. 13.

5. Attach the cartridge holder by placing it against the tonearm head as shown in Fig. 11, lift up flush against the bottom of the tonearm head, then lock it by pressing the tonearm lift forward.

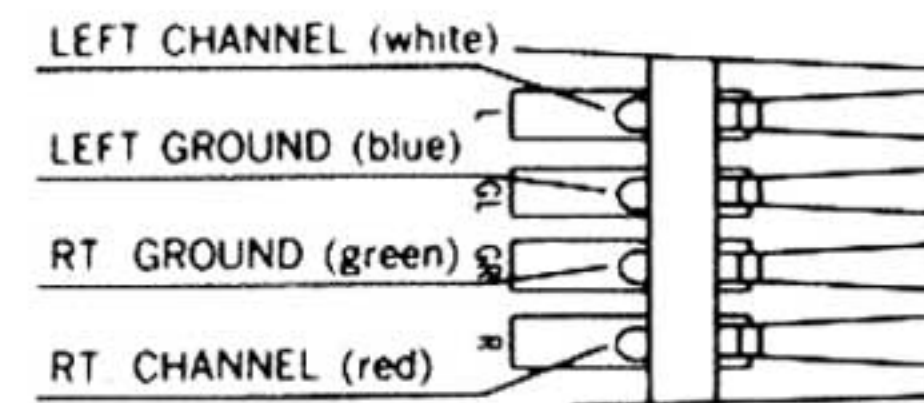

**Fig. 13. Cartridge lead connections.**

## Connections to amplifier.

1. The black phono cable is for the right channel, the white cable for the left channel.

2. Connect the ground wire of your Dual to the grounding screw on the rear of your amplifier.

## Connections to power supply.

You can plug the line voltage cord of your Dual either into the convenience outlet on the back of your amplifier or directly into a house outlet. If the amplifier AC outlet is switched, the amplifier's on/off switch will control the power to the Dual.

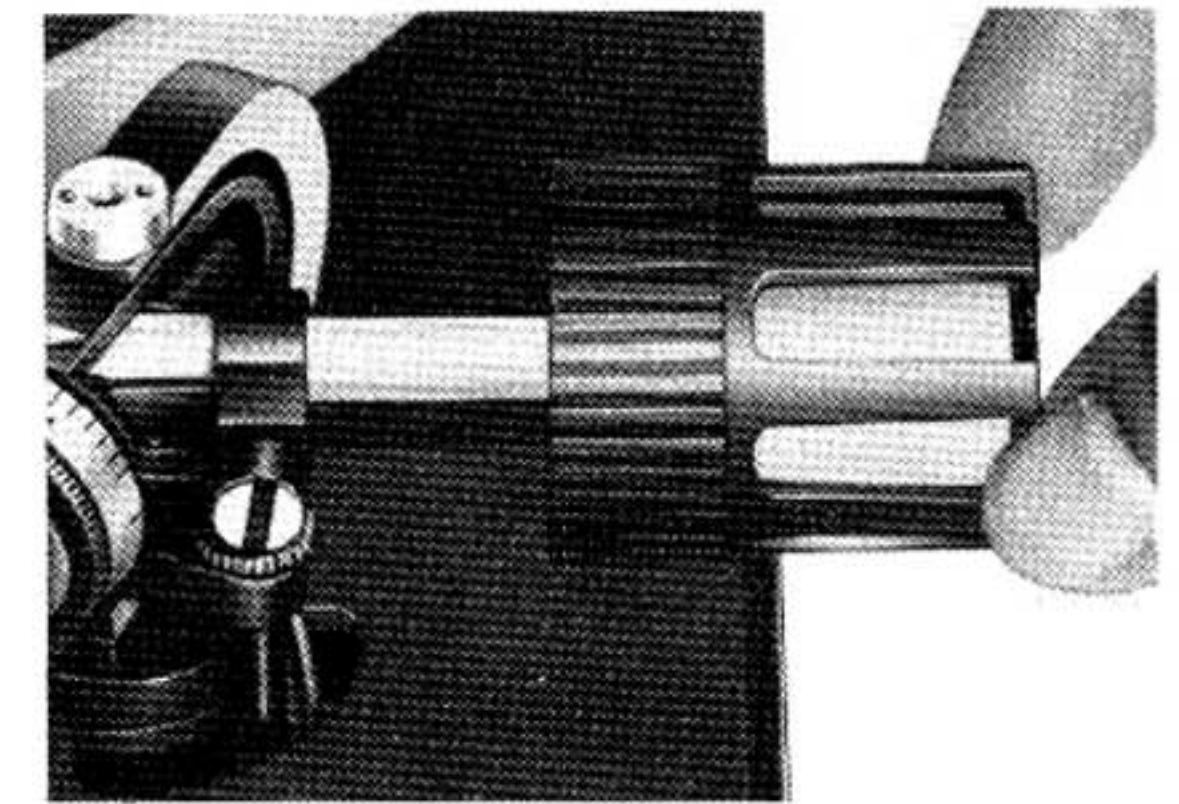

**Fig. 14.**

## Balancing the tonearm.

1. With the tonearm locked and the stylus force and anti-skating dials set at 0, slip the shaft of the counterbalance onto the rear of the tonearm, guiding it on by the V-shaped track. Do not tighten the set-screw.

2. To make sure the operating switch is in "neutral," move the operating switch to "start," then rotate the platter by hand two or three times.

3. Unlock the tonearm and move it to the inside. (It will be free floating after it passes through the switch-on position.) Then note if the tonearm floats either up or down.

4. Slide the counterbalance back and forth until the tonearm is approximately balanced for the weight of the cartridge. Then tighten the set-screw.

5. For fine balance, turn the counterbalance until the tonearm floats freely.

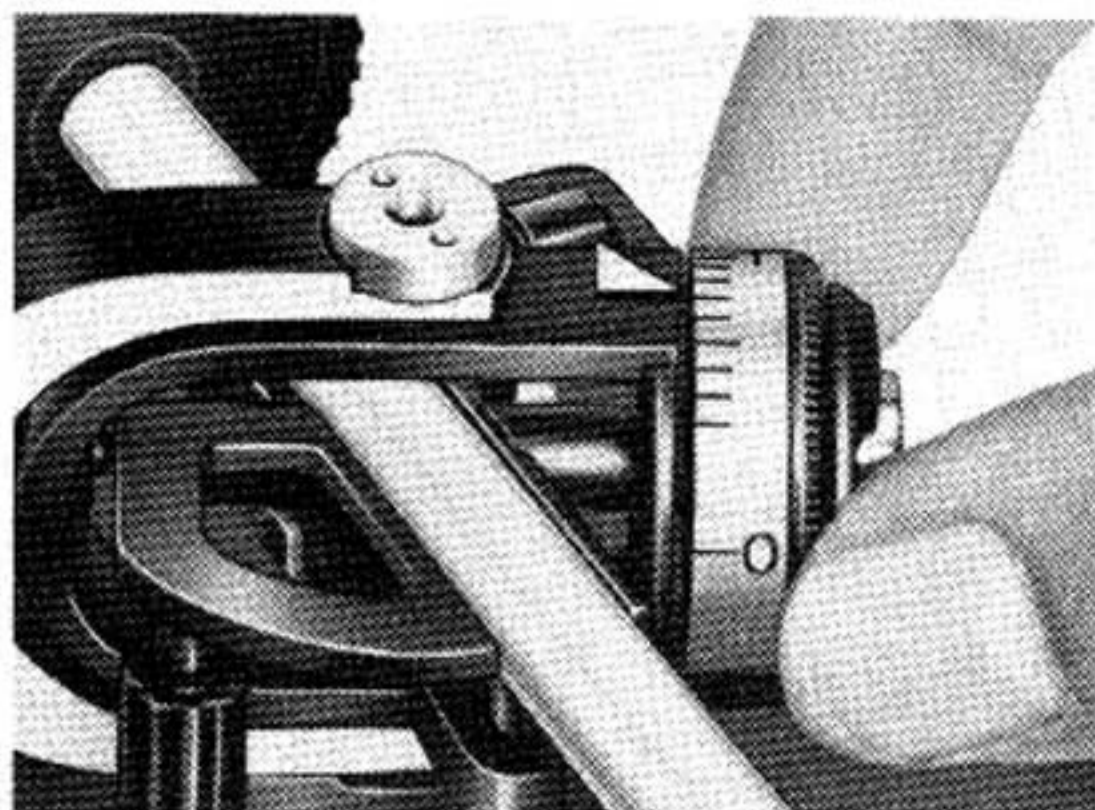

Fig. 15.

### Applying stylus pressure.

Place the tonearm on the rest post and dial the pressure recommended for your cartridge.

Stylus pressure can be set to any value from 0 to 3.0 grams. Between 0 and 1.5 grams, the dial is calibrated in increments of 0.1 gram; between 1.5 and 3.0 grams, in increments of 0.25 gram.

**Note:** The Dual 701 tonearm can track at a force as low as 0.25 gram. However you should not actually attempt to track at so low a pressure, as this is below the optimum tracking pressure of any cartridge available today. In all cases, the tracking ability of the cartridge you select will determine the best stylus pressure to use.

It is usually wise to set stylus pressure toward the higher end of the range suggested by the manufacturer of your cartridge. If loud passages with a good record sound clean, you can reduce the pressure slightly, but listen for the harshness or fuzziness that occurs with insufficient tracking force.

Too light a tracking pressure produces distortion, and also produces groove skipping and excessive record wear. Too heavy a tracking pressure restricts the ability of the stylus to follow the contours of the groove and can also cause excessive record wear.



Fig. 16.

### Applying anti-skating

The anti-skating dial is calibrated with two sets of numbers; red for conical styli, white for elliptical styli.

Using the appropriate scale for the stylus in your cartridge, dial the

anti-skating knob to the number which corresponds to the stylus pressure that you previously set.

### Adjustable cue-control height.

The height of the tonearm over the record when lifted by the cue-control is adjustable from approximately 0mm to 6mm. This height is preset at the factory at the center of this range. If you would prefer the height to be lower, turn the height adjustment knob clockwise. To increase the height, turn the knob counterclockwise.

### Adjusting indexing position.

Your Dual 701 has been set at the factory for the stylus to lower into the lead-in grooves of 12" and 7" records when you set the motor speed at 33-1/3 and 45 rpm respectively.

If your stylus touches down either inside or outside the lead-in grooves, the adjustment is made as

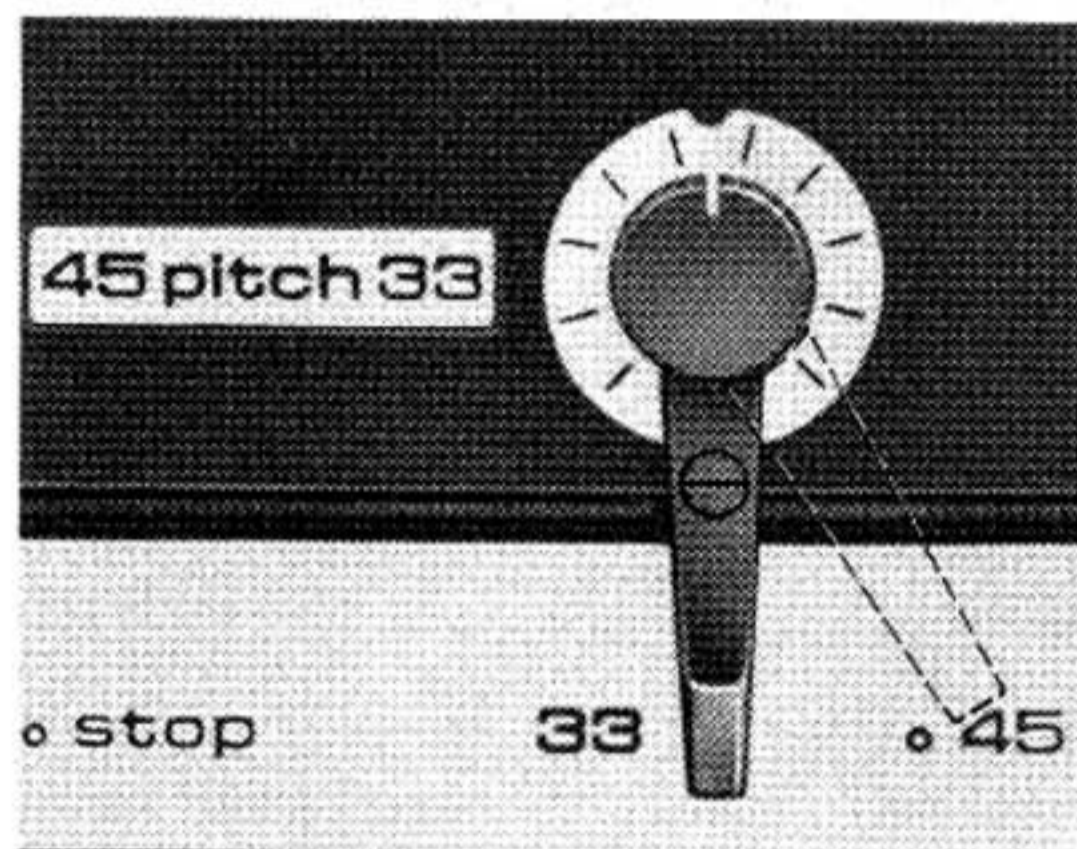

Fig. 17.

follows: Set the motor speed to 45 rpm. This will expose the adjustment screw (17) through the hole in the chassis. Turning the screw clockwise will move the setdown position toward

the center of the record, and vice versa. This procedure simultaneously corrects the indexing position for 12" records.

### Servicing

All lubrication points of the Dual are supplied with sufficient oil to permit years of operation under normal conditions. Do not add oil at any point, as special lubricants are used. If your Dual should ever need maintenance, please take it to your dealer or ask him for the name of the nearest authorized Dual Service Station. This will assure that only proper Dual parts are used. When shipping your Dual, use the original packing in order to prevent damage in transit. If the original packing has been discarded, write for special shipping instructions.



Dual Gebrüder Steidinger · 7742 St. Georgen/Schwarzwald

231 342  
Edit 1073